

NO. 200 GASOLINE-INSTANT LIGHTING LANTERN

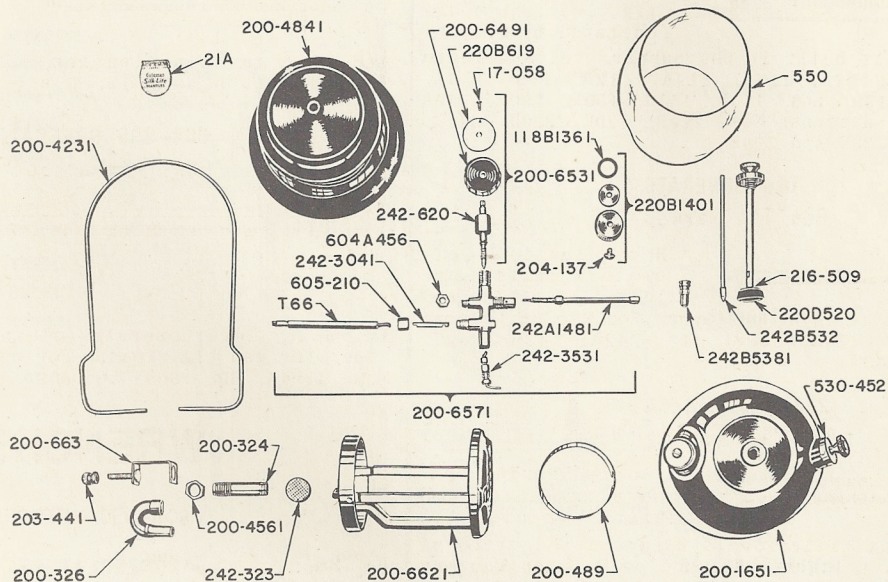

<u>NO.</u>	<u>NOMENCLATURE</u>	<u>NO.</u>	<u>NOMENCLATURE</u>
**21A	Mantle	203-441	Nut (Ball)
**T66	Generator (Marked "G")	204-137	Screw (Stl. Mach. 10-32 x 1/4" R.H.)
**550	Globe (Pyrex)	216-509	Leather (Pump)
17-058	Screw (Brass-Mach. 4-36 x 1/4")	220B1401	Plug (Filler)
118B1361	Gasket (Filler Plug)	220B619	Disc (Direction)
200-1651	Fount Ass'y.	220D520	Plunger Ass'y.
200-324	Tube (Burner)	242-3041	Block (Eccentric)
200-326	"U" Tube	242-323	Cap & Screen (Burner)
200-4231	Bail	242-3531	Stem (Tip Cleaner)
200-4561	Nut (Lock)	242-620	Packing (Valve Stem)
200-4841	Ventilator	242A1481	Tube Ass'y. (Fuel & Air)
200-489	Base Rest	242B532	Stem (Pump Air)
200-6491	Wheel	242B5381	Valve (Check)
200-6531	Stem (Valve)	530-452	Screw (Sht. Mtl. Type Z - Bd. Hd. #2 x 3/16")
200-6571	Valve Ass'y.	604A456	Nut (Hex. Mach.-Tapped 1/4-20-7/16" x 3/16")
200-6621	Frame Ass'y.	605-210	Nut (Jamb)
200-663	Bracket (Ventilator)		