



Coleman® Fuel Lanterns

Instructions for use



200BA65J
200BA66J

Coleman Limited One-Year Warranty

The Coleman Company, Inc. ("Coleman") warrants that for a period of one year from the date of original retail purchase, this product will be free from defects in material and workmanship. Coleman, at its option, will repair or replace this product or any component of the product found to be defective during the warranty period.

Replacement will be made with a new or remanufactured product or component. If the product is no longer available, replacement may be made with a similar product of equal or greater value. This is your exclusive warranty.

This warranty is valid for the original retail purchaser from the date of initial retail purchase and is not transferable. Keep the original sales receipt. Proof of purchase is required to obtain warranty performance. Coleman dealers, service centers, or retail stores selling Coleman® products do not have the right to alter, modify or in any way change the terms and conditions of this warranty.

What This Warranty Does Not Cover

This warranty does not cover normal wear of parts, parts that are not genuine Coleman® parts, or damage resulting from any of the following: negligent use or misuse of the product; use on improper voltage or current; commercial use of the product; use contrary to the operating instructions; disassembly, repair or alteration by anyone other than Coleman or an authorized service center. Further, the warranty does not cover Acts of God, such as fire, flood, hurricanes and tornadoes. Warranty void if damage to product results from the use of a part other than a genuine Coleman® part.

COLEMAN SHALL NOT BE LIABLE FOR DEFECTS THAT ARE CAUSED BY THE USE OF UNAUTHORIZED PARTS OR SERVICE. COLEMAN SHALL NOT BE LIABLE FOR ANY INCIDENTAL OR CONSEQUENTIAL DAMAGES CAUSED BY THE BREACH OF ANY EXPRESS OR IMPLIED WARRANTY OR CONDITIONS. EXCEPT TO THE EXTENT PROHIBITED BY APPLICABLE LAW, ANY IMPLIED WARRANTY OF MERCHANTABILITY OR FITNESS FOR A PARTICULAR PURPOSE IS LIMITED IN DURATION TO THE DURATION OF THE ABOVE WARRANTY OR CONDITIONS. SOME STATES, PROVINCES, OR JURISDICTIONS DO NOT ALLOW THE EXCLUSION OR LIMITATION OF INCIDENTAL OR CONSEQUENTIAL DAMAGES OR LIMITATIONS ON HOW LONG AN IMPLIED WARRANTY LASTS, SO THE ABOVE LIMITATIONS OR EXCLUSIONS MAY NOT APPLY TO YOU. THIS WARRANTY GIVES YOU SPECIFIC LEGAL RIGHTS, AND YOU MAY ALSO HAVE OTHER RIGHTS THAT VARY FROM STATE TO STATE OR PROVINCE TO PROVINCE.

How to Obtain Warranty Service

Take the product to an authorized Coleman service center. You can find the nearest authorized Coleman service center by visiting www.coleman.com or calling 1-800-835-3278 or TDD 316-832-8707 in the United States or 1 800 387-6161 in Canada. If a service center is not conveniently located, attach to the product a tag that includes your name, address, daytime telephone number and description of the problem. Include a copy of the original sales receipt. Carefully package the product and send either by UPS or Parcel Post insured with shipping and insurance prepaid to:

For products purchased in the United States:
The Coleman Company, Inc.
3600 North Hydraulic
Wichita, KS 67219

For products purchased in Canada:
Sunbeam Corporation (Canada) Limited
5975 Falbourne Street
Mississauga, Ontario
Canada L5R 3V8

The costs of transporting the product to Coleman or an authorized service center for warranty service is the responsibility of the purchaser.

Do not mail products with fuel in tanks, or with disposable propane cylinders. Remove glass globes from lanterns and wrap separately.

DO NOT RETURN THIS PRODUCT TO THE PLACE OF PURCHASE.

If you have any questions regarding this warranty please call 1-800-835-3278 or TDD 316-832-8707 in the United States or 1 800 387-6161 in Canada.

© 2005 The Coleman Company, Inc. All rights reserved. Coleman®,  and the shape of the lantern are registered trademarks of The Coleman Company, Inc.

200A055J (7/15/05) P.I.

Parts List

No.	Part No.	Description
1	282-5341	Burner Assembly
2	231A3111	Spring Clip
3	200-3111	Burner Tube and Retainer Assembly
4	21A	Mantle
5	285A5891	Generator
6	286A6571	Valve Assembly
7	200-1521	Knob Assembly
8	200B4301	Frame Bottom and Bolt Assembly
9	286-1151	Heat Shield
10	200-5371J	Collar Assembly
11	220C1401	Filler Cap
12	220A6201	Pump Plunger Assembly
13	200-0461	Globe
14	200B4901	Ventilator Assembly (Black) (Includes Bail)
15	220A4411	Ball Nut

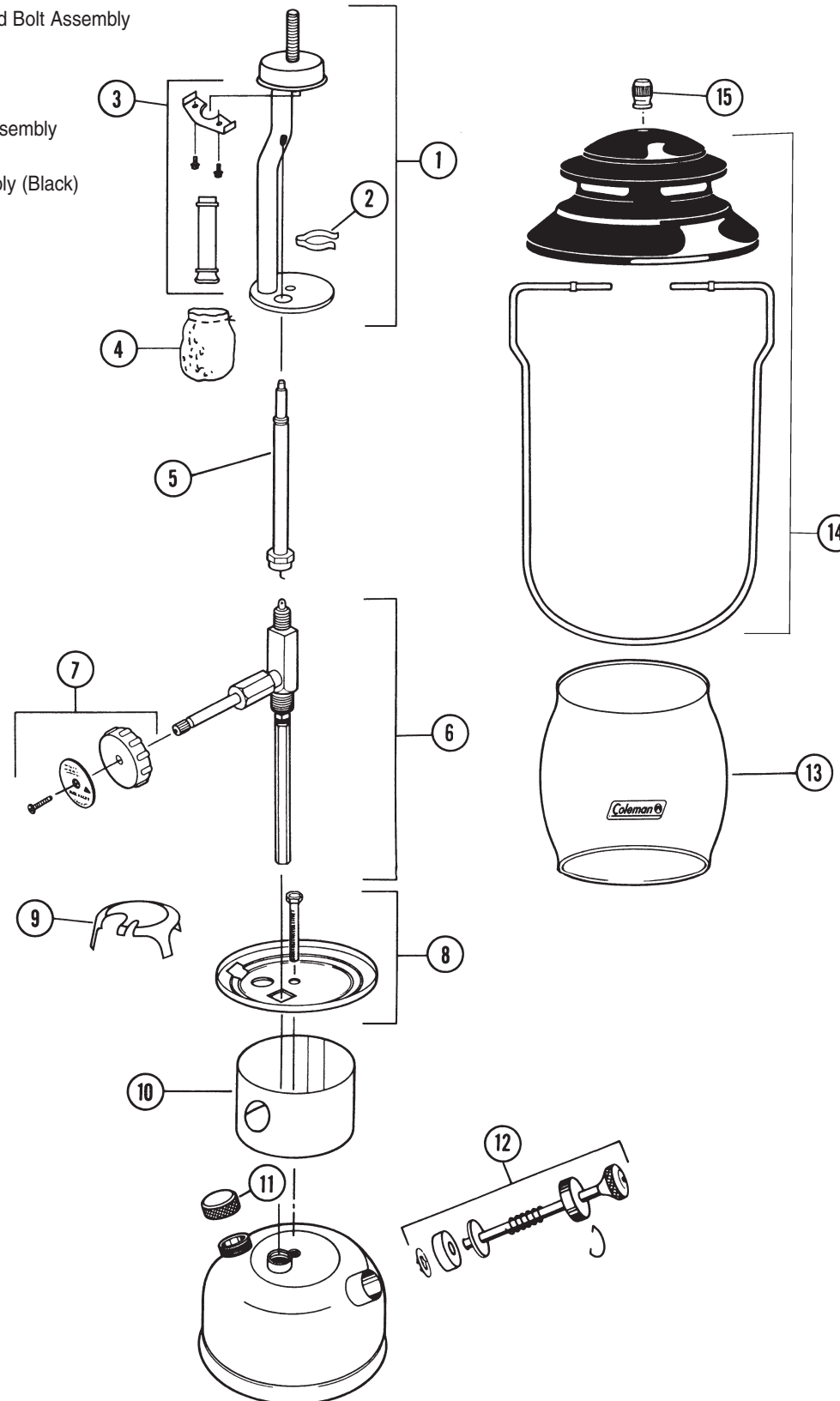

Things you should know

1. Carry a spare set of Coleman® Mantles. Once burned, a mantle is fragile and can be damaged if touched or dropped.
2. For best results, use only Coleman® Fuel in this lantern. Coleman Fuel is especially formulated and tested to rigid specifications for long storage life and includes a rust inhibitor to help prevent corrosion. Use of other fuels including unleaded automotive fuel may shorten generator life, damage lantern, and result in unsatisfactory performance.
3. Rinse tank occasionally with fresh fuel to remove sediment, gum formations, and moisture accumulations. If lantern is to be used for standby service, rinse and refill annually with fresh fuel.
4. Oil pump periodically to keep it working smoothly.
5. Part of the brightness control is located in the generator. If the lantern fails to adjust from high to low properly, replace the generator.
6. The usual storage areas for camping and picnic equipment are the basement, attic, or garage. To avoid the accumulation of dust, cobwebs, etc., that is common in these storage areas, place your lantern in a plastic bag and seal it with a rubber band.
7. For repair service, call 1-800-835-3278 TOLL FREE (TDD:316-832-8707) for the location of your nearest Coleman Service Center. If lantern must be mailed to Service Center, attach your name, address, and a description of problem to product and mail to Service Center prepaid, less globe and ventilator to prevent breakage. If necessary to write the Service Center or factory, refer to your lantern by model number.
8. If not completely satisfied with performance of this product, please call the toll-free number listed above. Do not return the product to the store where purchased.



Follow instructions and warnings to avoid fires, serious injury, or death.

⚠ WARNING:

1. Coleman® fuel is extremely flammable, handle with extreme care. Fuel vapors are invisible, explosive, and can be ignited by ignition sources many feet away.
2. This lantern is designed to use Coleman fuel. Never use kerosene, unleaded or leaded automotive fuel.
3. Store fuel in a clean, properly marked container away from flame (including pilot lights), other sources of ignition, or excessive heat.
4. Always fill outdoors. Never fill lantern, loosen or remove fuel cap while lantern is lighted, near flame (including pilot lights), other ignition sources, or while top of lantern is hot to touch.
5. Always light and use lantern outdoors; never inside house, camper, tent, or other unventilated or enclosed areas.
6. This lantern consumes air (oxygen). Do not use in unventilated or enclosed areas to avoid endangering your life.
7. Keep lantern away from flammables. Never allow fabric, clothing, or any flammable material to come within 4 ft. (1.2 m) of the top and 1 ft. (30 cm) of the side of the lantern.
8. Use for lighting only. Never alter in any way or use with any device or part not expressly approved by Coleman. Do not use as a space heater.
9. Replace any mantle with a hole in it. A hole can cause lantern to overheat and create a hazard.
10. Keep out of reach of children.

Filling the lantern

- Always fill outdoors. Never fill lantern, loosen or remove fuel cap while lantern is lighted, near flame (including pilot lights), other ignition sources, or while top of lantern is hot to touch.
- Turn FUEL VALVE to OFF.



■ Close PUMP KNOB firmly. Turn in direction of arrow.

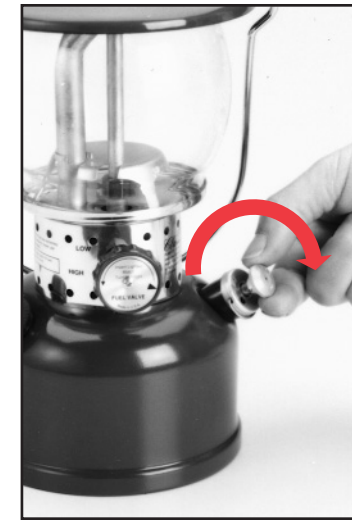

- Remove FUEL CAP. Use a funnel or suitable filling device and fill with clean, fresh fuel. Lantern must be in a level position. DO NOT TIP.
- Replace FUEL CAP on lantern and on fuel container. Tighten firmly. WIPE UP ANY SPILLED FUEL AND DISPOSE OF IN A SAFE PLACE.

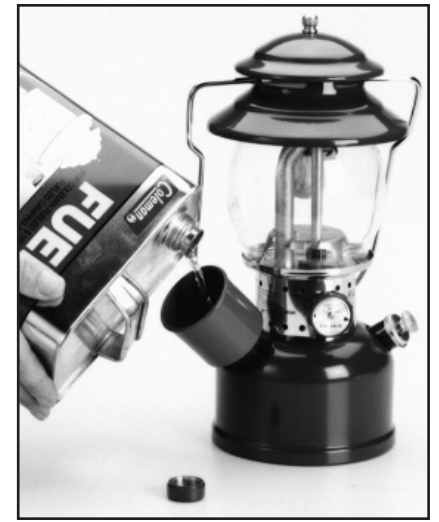

To tie on mantle

- Always use genuine Coleman® mantles. Replace damaged mantles to avoid overheating or damaging lantern.
- Unscrew ball nut at top of lantern and remove ventilator and glass globe.



- Tie mantle around groove in burner and cut off ends of string 1/4" (.64 cm) from knot.



- Light bottom of mantle evenly (move match back and forth) and leave to burn. Once mantle has been burned it is very fragile. Be careful not to touch it with your finger or with a match.



- Replace the glass globe, ventilator and ball nut.



Pumping

- Be sure fuel valve is off and fuel cap is firmly closed.



- Open pump knob by turning 1 full turn to the left.



- Cover hole in pump knob with thumb and pump approximately 30 full strokes.



- Close pump knob.



Lighting the lantern

- Always light and use your lantern outdoors; never in house, camper, tent or other unventilated or enclosed areas.
- Push a lit match through lighting hole and turn fuel valve to high. CAUTION: Flames other than at mantle indicate flooding or a leak. Turn FUEL VALVE OFF, allow flames to burn out and lantern to cool. Carefully review instructions and correct problem before relighting lantern.



- Open pump knob and pump 15-25 strokes. Close pump knob.
- Adjust fuel valve to desired brightness.
- To clean generator tip, turn fuel valve from high to off to high several times.
- Good air pressure is important. Maintain pressure by periodic pumping.

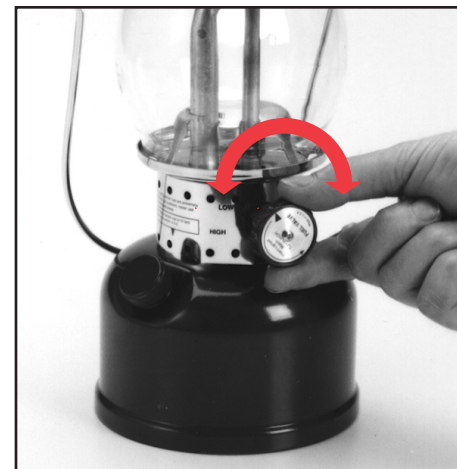

To Turn Off

- Turn the lantern off by turning fuel valve to "OFF." Light will dim and go out in 1-2 minutes.

